

The influence of adhesive on the Al alloy in laser weld bonding Mg–Al process

H. Y. Wang · L. M. Liu · Z. Y. Jia

Received: 28 January 2011 / Accepted: 21 March 2011 / Published online: 30 March 2011
© Springer Science+Business Media, LLC 2011

Abstract Laser weld bonding is a new welding technology, being used to join Mg–Al alloys. The penetration depth of LWB Mg–Al joint was larger than that in simply laser welding joint in same welding parameters. The temperature at the edge of the Al fusion zone in LWB Mg–Al joint was higher than that in laser welding joint, which was measured through the thermal couples. The laser-introduced plasma in LWB Mg–Al process is observed by the high-speed camera, which is different from that in laser welding process. The surface temperature and state of the Al alloy were changed because of the addition of the adhesive, thus the laser absorptive of Al alloy was increased in LWB process, comparing with that in laser welding process; and the decomposition of the adhesive would make a depression in the Al fusion zone, which would be beneficial to the formation of keyhole welding in LWB Mg–Al joint.

Preface

The demand of the transportation industries for lightweight structures is increased by the requirements of weight savings, improvement of fuel efficiency and reduction of atmospheric pollution [1, 2]. To meet legislative regulations and market needs and to retain competitiveness of their products, manufacturers have been forced to explore advanced materials and joining techniques [3, 4]. The use of Al and Mg in automotive and aircraft applications is

growing owing to advantageous properties of these alloys, including high stiffness to weight ratio, good formability, and recycling potential [5–7]. Therefore, the joining technology of Mg alloy and Al alloy is of great significance for the industrial production. Now several kinds of welding techniques are used to join Mg alloys to Al alloys, such as tungsten inert gas welding (TIG), laser welding, laser-TIG hybrid welding, diffusion bonding, and Friction stir welding (FSW) techniques [8–14]. Some new kinds of hybrid welding methods are used to join Mg–Al alloy, such as laser weld bonding technology [15].

Laser weld bonding (LWB) is a new kind of welding method, which is put forward as an alternative to laser welding and adhesive bonding [16]. Adhesives provide excellent stress distribution over large bonding areas, and welds improve the peel resistance of adhesives. A synergy develops in which the tensile and peel performance of the weld-bonded structure exceeds that of either technology alone. The manufacture of aircraft skin structures by a combination of adhesives and laser spot welding is reportedly under development at the Edison Welding Institute [17]. It was used to join Mg–Al alloys successfully, and the addition of the adhesive changed the element distribution of the Mg–Al intermetallics, therefore the property of the joint was increased.

The surface tension and the characteristic of the alloy made obviously effect on the laser welding process. In LWB Mg–Al process, the adhesive is put on the surface of the Al alloy. The addition of the adhesive not only changed the microstructures of the joint but also made the whole LWB process different from that of laser welding process. This paper primarily studies the effect of the adhesive on the Al fusion zone in LWB Mg–Al process, comparing with that in the laser welding process. It would be helpful for the further understanding of the effect of the surface

H. Y. Wang · L. M. Liu (✉) · Z. Y. Jia
Department of Materials Science and Engineering, Key
Laboratory of Liaoning Advanced Welding and Joining
Technology, Dalian University of Technology, Dalian, China
e-mail: Liulm@dlut.edu.cn

state on the interaction between the laser beam and the light metals during welding process.

Experiments

Samples of extruded AZ31 Mg alloy ($60 \times 30 \times 1.2$ mm) and 6061Al alloy ($60 \times 30 \times 1.7$ mm) were used in experiments. The experiments were carried out using a pulsed Nd-YAG laser with a maximum average output power as 500 W. The laser power in the experiment was about 350 W. The welding speed was 400 mm min^{-1} . The defocusing amount was -3.5 mm. The configuration of the LWB specimens is shown in Fig. 1. The adhesive used in experiment was epoxy adhesive made by Henkel Co, whose thickness was about 0.1 mm in the experiment. Oxide film on the specimen surface was removed by 800 grids emery paper before welding, then degreased by acetone and trichloroethylene. Laser welding Mg–Al alloy joint was done in same parameters.

After welding, specimens for the weld shape observation were prepared and etched to reveal the bead shape and size. The cross-sections of the weld bead were investigated by scanning electron microscopy (SEM). The Al surface temperatures were recorded by the thermal couples with a sampling rate of 2 s^{-1} . A high-speed camera (CPL 250 K CMOS) with the sampling frequency of 1072 frames/s was placed at the vertical direction to weld seam to monitor the behavior of the welding plasma. No technique to filter the light from the laser was used to enhance these images. The experiments were done both in LWB and the laser welding Mg–Al processes.

Results and discussion

Penetration depth in Al fusion zone

The penetration depths of LWB and laser welding Mg–Al joints are shown in the Fig. 2. It could be seen that the

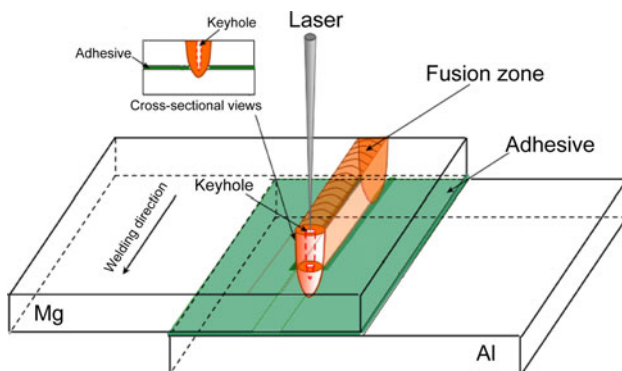

Fig. 1 Configuration of the laser weld bonding Mg–Al specimen

penetration depth in the LWB Mg–Al joint is obviously larger than that in the laser welding joint, especially for the penetration depth in the Al alloy. The Mg alloy was wholly melted during the LWB process and the laser welding process, but the laser welding mode in the Al alloy for these two joints were different. The welding mode in Al fusion zone was a conductive mode in laser welding Mg–Al joint and approximately a keyhole mode in LWB Mg–Al joint. The penetration depth in Al fusion zone was directly affected by the laser beam power being absorbed by the Al alloy. Both the LWB joint and laser welding joint were obtained in same parameters. Therefore, the increase of penetration depth in LWB Mg–Al joint was caused by the temperature build-up in the Al fusion zone; and the temperature on the Al alloy surface was measured through the thermal couples.

Figures 3 and 4 show the results of the measurement of the Al alloy surface temperature in laser welding and LWB Mg–Al process with thermal couple. It was exhibited that the Al alloy surface temperature during LWB process was higher than that in laser welding process. The cooling rate in LWB process was higher than in that laser welding process. The temperature distribution in LWB fusion zone was different from that in laser welding fusion zone. It could be deduced that the temperature difference between the LWB fusion zone and laser welding fusion zone were even larger. There as no difference between the LWB and laser welding parameters, except the addition of adhesive. Therefore, the increase of temperature in LWB Al fusion zone was mainly caused by the addition of the adhesive, which would change the surface state of the Al alloy.

The effect of adhesive on the surface state of Al alloy

In order to explain the effect of the adhesive on the surface state of the Al alloy, a contrivable experiment was done in this study. Laser bead welding were carried both on the Al alloy and the Al alloy with adhesive coating in same welding parameters. Figure 5 shows the fusion zone of laser bead welding Al joint with adhesive coating was about 0.433 mm which was nearly 1.5 times of that in simply laser welding Al joint 0.266 mm. It meant that the addition of the adhesive coating could increase the laser absorptive of Al alloy in laser welding process. Consequently, the addition of the adhesive would change the surface state of Al alloy in LWB Mg–Al process, which would be even more obviously than that in laser bead welding Al process.

In order to further understand the effect of the adhesive in laser weld bonding process, the laser-induced plasma morphologies in different welding conditions were observed. Figure 5 shows the diagram of the laser-induced

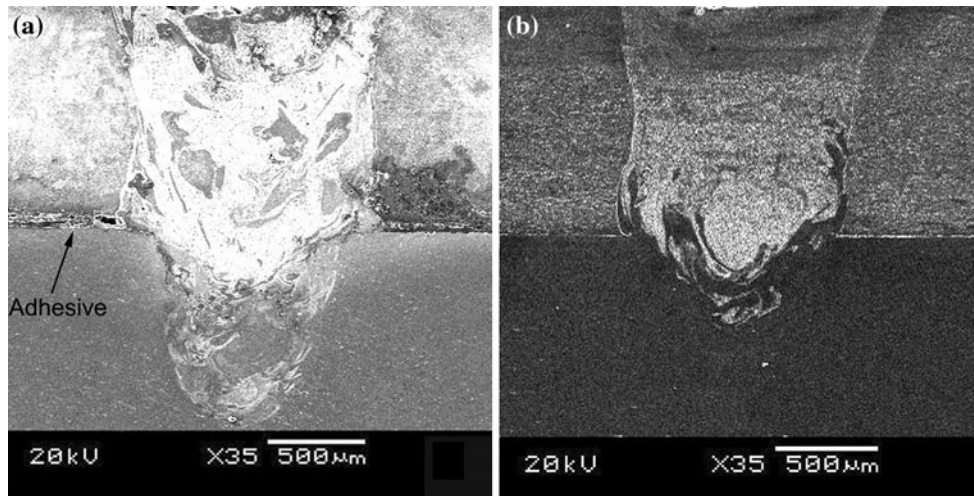

Fig. 2 Penetration depths in LWB and laser welding Mg–Al joint. **a** LWB joint **b** laser welding joint

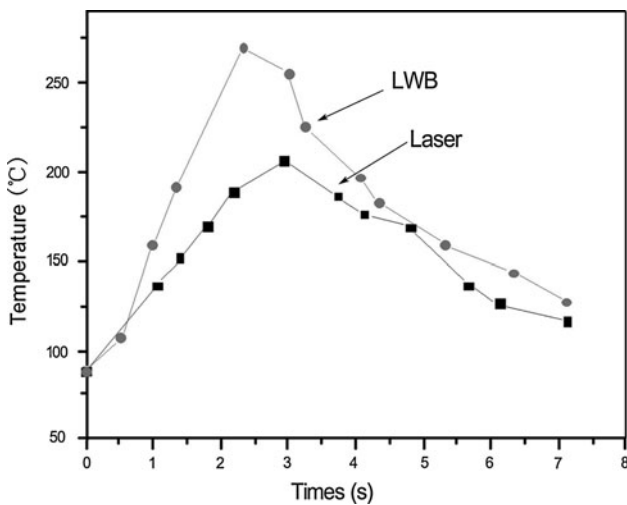

Fig. 3 Results of the temperature on the surface of the Al alloy through the thermal couple

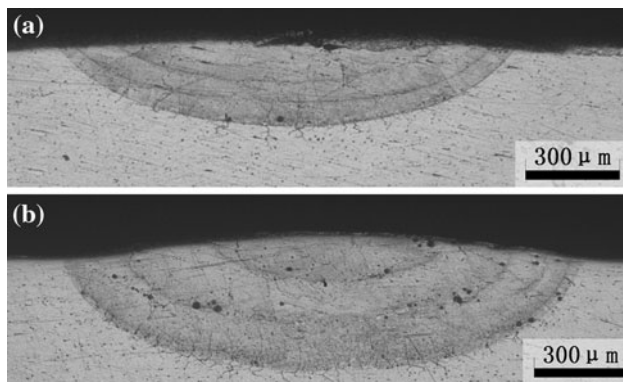

Fig. 4 Penetration depths in laser bead welding of Al alloy and Al alloy with adhesive coating, **a** laser bead welding of Al alloy, **b** laser bead welding of Al alloy with adhesive coating

plasma observation system. Figure 6 shows the laser-induced plasma morphology in laser bead welding process for Al alloy only and Al alloy with adhesive coating. As the pulse laser power was about 2900 W, the laser-induced plasma was very small and unclear in laser welding Al alloy process. But the laser-induced plasma had a clear and continuous morphology in the laser welding Al alloy with adhesive coating process. For the YAG laser beam ($f = 1.06 \mu\text{m}$), the laser reflection ratios of Al and its alloys was nearly the 90%. Thus, the laser-induced plasma morphology in laser welding Al process was very small. But in laser welding process of Al with adhesive coating, the surface state of Al alloy was great different from that in the simply laser welding process, and the laser-induced plasma morphology in this process would be enhanced. The laser-induced plasma observed in the laser welding Al alloy with adhesive coating process was not only the ionized Al ions but also some adhesive decomposed vapor.

Figure 7 shows the laser-induced plasma morphology in laser welding Mg–Al process and LWB Mg–Al process. The laser-induced plasma in LWB process was relatively

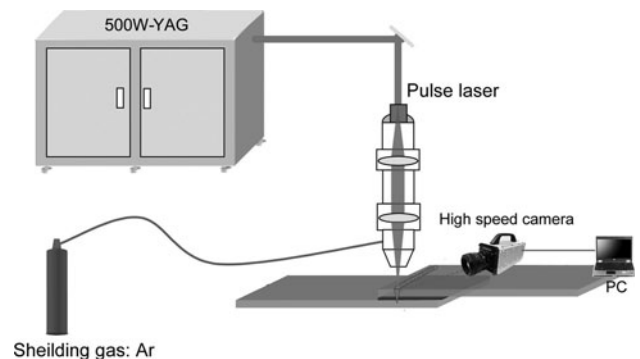

Fig. 5 The diagram of the laser-induced plasma observation system

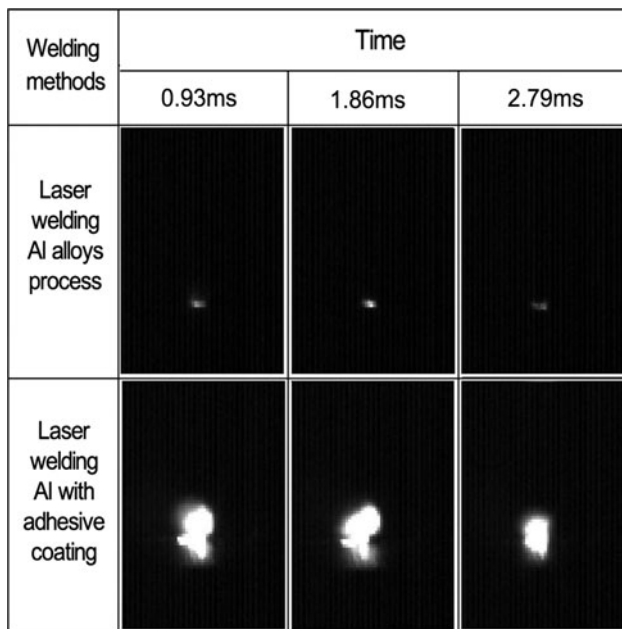

Fig. 6 Laser-induced plasma morphology in laser welding Al alloy and laser welding Al alloy with the adhesive coating

larger than that in laser welding process. Further more the brightness of laser-induced plasma in LWB process was a little higher than that in laser welding process. Seen from the results of the contrast experiments, it could be found that the addition of the adhesive would change the surface state of the Al alloy, which would enhance the ionization in laser welding process.

There was a high density of free electrons in the Al alloy. The free electrons would generate secondary wave with effect of the laser photons, which would reduce the

absorptivity of the laser alloy obviously. However, for the adhesive a high-molecular polymer, there was nearly no free electron. The power of laser beam would transform to the adhesive through energy coupling of the crystal lattice or organic molecules vibration. Therefore, the addition of the adhesive would change the interaction between laser beam and the Al alloy so that more laser beam power was absorbed by Al alloy in extent.

The effect of adhesive on keyhole formation in LWB Mg–Al process

Figure 8 shows the pulse waveform of laser beam used in welding process. The pulse laser power density could be calculated through Formula 1 as shown below:

$$P_{\text{pulse}} = \frac{P_a}{t_{\text{pulse}} \times \pi r^2 \times f} \tag{1}$$

In this study the pulse time of laser welding (t_{pulse}) was 3.6 ms and the radius of laser spot (r) was 0.03 cm. The average laser beam power (P_a) was 300 W which was measured by a Laser Power Meter. The pulse laser power density (P_{pulse}) was $7.37 \times 10^5 \text{ W/cm}^2$ in welding process. If the keyhole welding mode was generated during laser welding process, the laser power density should be over 10^6 W/cm^2 , which was obviously larger than that in LWB Mg–Al joint. Although the surface state of the Al alloy was changed by the addition of the adhesive, the pulse laser power was still not enough for a keyhole mode formation in Al alloy during LWB Mg–Al process. Therefore, the formation of the keyhole formation in the al alloy was mainly decided by another effect of the adhesive in LWB Mg–Al process.

Fig. 7 Laser-induced plasma morphology in laser welding and LWB Mg–Al process

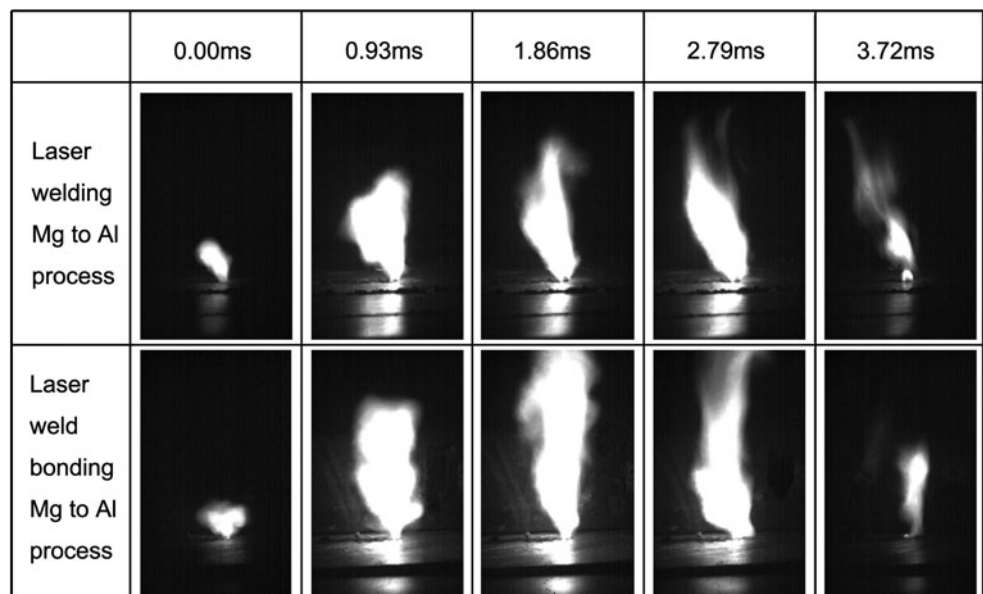

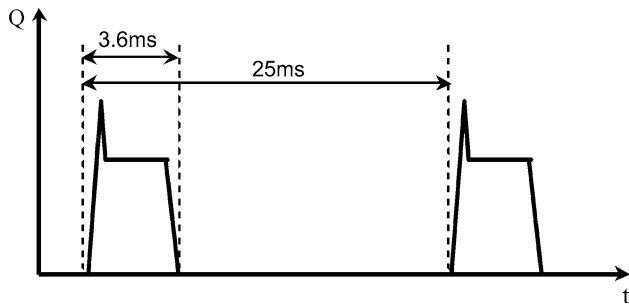
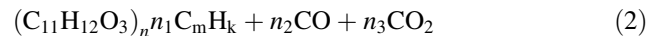

Fig. 8 Pulse waveform in LWB and laser welding Mg–Al process

It was known that for all laser welding irrespective of the type of laser employed, laser energy was absorbed at the surface of the metal. If the intensity was high enough, vaporization occurred with some of the metal electrons becoming free (ionization). These free electrons then absorb energy directly. This results in higher temperatures, increased ionization and increased absorption leading to vaporization of the surface which formed a depression in the workpiece. As the depression deepens, a keyhole forms and the laser light was scattered repeatedly within it, so that energy could be absorbed at the keyhole walls too, thus increasing the coupling of laser energy into the workpiece. As the keyhole develops, the power of the source can now be absorbed at greater depths, not just at the surface [18]. Thus, the formation of keyhole in laser welding was mainly influenced by the vaporization, ionization and the depression in the work piece.

In laser welding Mg–Al process, the Mg alloy was wholly melted, and the vaporization and ionization of Mg alloy would occur during laser welding process. Therefore, a depression was generated in the Mg fusion zone, which formed keyhole welding in Mg alloy. However, the effect of vaporization and ionization of Mg alloy on Al alloy was limited, and vaporization and ionization couldn't occur in Al alloy during laser welding process because of the low laser power. Thus, the welding mode of Al in laser welding Mg–Al joint was in conductive mode. In LWB Mg–Al process, the welding mode of Mg was same with that in laser welding process, which was in a keyhole mode. However, the addition of the adhesive changed the surface state of the Al alloy which increased laser absorptive of Al alloy and changed the welding mode of Al alloy in LWB process. The adhesive was coated on the Al alloy, and the decomposition of the adhesive would be carried out on the surface of the Al fusion zone. Still, the adhesive used in this experiment was a kind of polymer, whose main content was Bisphenol-A-Epichlorohydrin polymer ($(C_{11}H_{12}O_3)_n > 60\%$). It would be decomposed with the thermal effect of laser welding. Its reaction equation is showed below:



Several kinds of gases such as carbon monoxide, carbon dioxide, and hydrocarbon would be forming during this process. Hence, the volume of the decomposed adhesive would increase rapidly in welding process, which would escape from the keyhole in LWB process. Thus, the decomposition of the adhesive volume rapidly increasing would make a depression in the Al fusion zone, which would play same role as the high temperature plasma in laser welding. The addition of the adhesive would increase the laser absorptive of Al alloy and the adhesive decomposition would make a depression in the Al fusion zone, which would be beneficial to the formation of keyhole welding in LWB Mg–Al joint. In order to know the recoil pressure (P_r) of the adhesive decomposition, it was measured as below process.

The recoil pressure in laser welding process could be proportional to the saturated vapor pressure p_s [19, 20], which in turn depends on the melt's surface temperature T_s [21]:

$$P_r = A p_s(T_s) = A B_0 T_s^{-1/2} \exp(-U/T_s) \quad (3)$$

where A is a numerical coefficient, B_0 is a vaporization constant, and $U = M_a L_v / (N_a k_b)$, M_a is the atomic mass, L_v is the latent heat of evaporation, N_a is Avogadro's number and k_b is Boltzmann's constant.

In the laser weld bonding process the effect of adhesive decomposition should be involved in the process. The adhesive was changed from liquid to gas in a flash. Therefore, the effect of the adhesive would be measured as below:

$$P_a = \frac{T_s \cdot N P_0}{T_0 M} \quad (4)$$

where T_s is the same as that shown in equation 3, T_0 is the initial temperature of the circumstance, P_0 is the surface vapor pressure of the adhesive in circumstance, N is the molecules number after the reaction and M is the molecules number before the reaction. Seen from the Eq. 4, the circumstance temperature T_0 was about 293 K, and the melt's surface temperature T_s was approaching to the melting point of Mg alloy which was about 923 K. Therefore, T_s/T_0 could be calculated as $923/293 = 3.15$. The adhesive pressure (P_a) should be mainly depends on the ratio of N and M , which should be equal to the $n_1 + n_2 + n_3$ in reaction Eq. 2. And the adhesive decomposition would make a depression effect on the Al fusion zone, which just like the metal vapor in simply laser welding process. Therefore, it would be possible to form a keyhole mode welding in Al alloy for LWB Mg–Al joint. In this study, the effect of adhesive on the surface state of Al alloy and the decomposition were discussed separately, but in

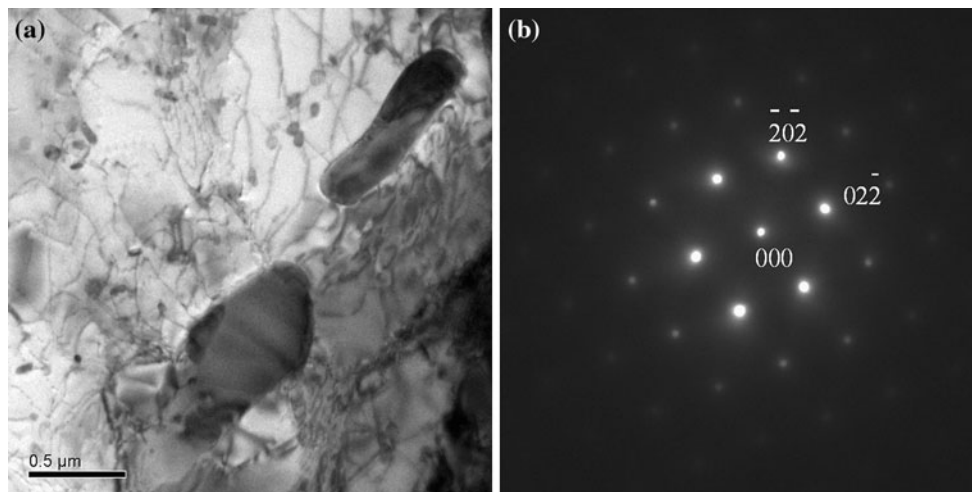

Fig. 9 The dislocation and deformation in Al fusion zone. **a** TEM morphology of dislocation in Al fusion zone. **b** Diffraction pattern of Al Alloy

actually the melted of Al alloy and adhesive decomposition occurred at the same time. There would be an obvious extruding effect on the Al alloy, which was composed of the recoil pressure of laser welding and the adhesive decomposition instantaneous. The dislocations and the deformation on Al crystal are shown in Fig. 9. It could be prove that there is an obvious effect on the Al fusion zone, which was decided by the laser welding and adhesive decomposition.

The adhesive was brushed on the surface of the Al alloy, thus the pressure effect should also make on the Mg fusion zone, which could make the interface between the Mg and Al alloy different from that in laser welding process. The microstructure of the LWB Mg–Al joint was different from that of the simple laser welding joint, especially for the interface between the Mg and Al alloy, as shown in the Fig. 10. There were obviously Mg–Al intermetallics forming in the laser welding Mg–Al joint, which made many micro-cracks in the Mg–Al interface. However, the adhesive change the penetration depth of the joint, and more hypereutectic Mg–Mg₁₇Al₁₂ phase formed in the LWB Mg–Al joint, which would decrease the tendency of

the micro-cracks in the fusion zone. Therefore, the property of the LWB Mg–Al joint was better than that of laser welding joint. After the adhesive was cured, the tensile shear load of the LWB joint was about 7.2 KN, as shown in the Fig. 11, which was nearly the 85% percent of the Mg–base metal tensile load.

Conclusions

The addition of the adhesive change the surface temperature and the surface state of the Al alloy, thus in LWB Mg–

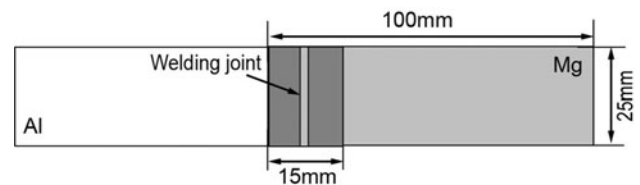

Fig. 11 The tensile shear specimen of laser weld bonding Mg–Al joint

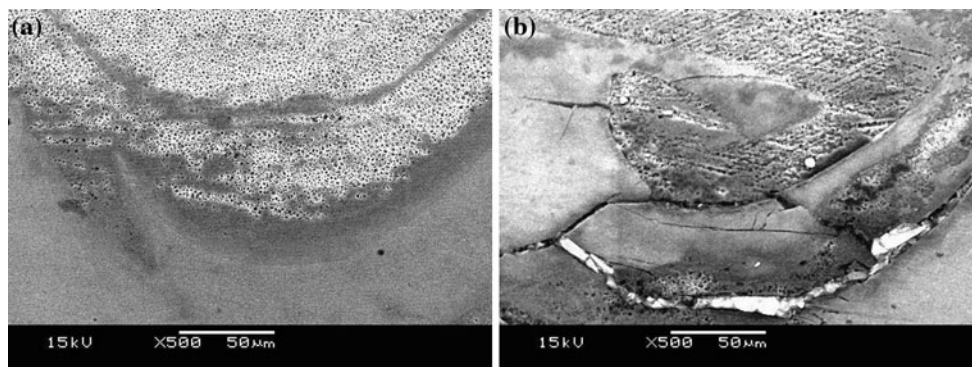

Fig. 10 The interface between Mg and Al in LWB and laser welding Mg–Al joints. **a** LWB Mg–Al joint, **b** laser welding joint

Al process, the welding penetration depth in Al alloy is increased, comparing with that of laser welding joint. Still the adhesive would be decomposed during laser welding process, the adhesive decomposition would make a depression in the Al fusion zone which would be beneficial to the formation of keyhole welding in LWB Mg–Al joint; and the microstructure of the LWB Mg–Al joint was better than that of laser welding joint.

Acknowledgements The authors really appreciate the supports from National Natural Science Funds for Distinguished Young Scholar (51025520) and Fundamental Research Funds for the Central Universities (DUT10ZD108).

References

1. Zhao H, White DR, DebRoy T (1999) *Int Mater Rev* 44:238–266
2. Hekmat-Ardakan A, Ajersch F, Chen X-G (2011) *J Mater Sci* 46:2370. doi:10.1007/s10853-010-5084-1
3. Braun R (2006) *Mater Sci Eng A* 426:250
4. Song G, Luo Z (2011) *Opt Laser Eng* 49:82
5. Hakamada M, Shimizu K, Yamashita T, Watazu A, Saito N et al (2010) *J Mater Sci* 45:719. doi:10.1007/s10853-009-3990-x
6. Qi X, Gang S (2010) *Mater Des* 31:605
7. Vaidya WV, Horstmann M, Ventzke V, Petrovski B, Koçak M et al (2010) *J Mater Sci* 45:6242. doi:10.1007/s10853-010-4719-6
8. Somasekharan AC, Murr LE (2004) *Mater Charact* 52:49
9. Yan J, Xu Z (2005) *Scr Mater* 53:585
10. Jiang JB, Zhang ZD (2008) *J Alloys Compd* 466:368
11. Dietrich D, Nickel D, Krause M, Lampke T, Coleman MP et al (2011) *J Mater Sci* 46:357. doi:10.1007/s10853-010-4841-5
12. Sato YS, Park SHC, Michiuchi M, Kokawa H (2004) *Scr Mater* 50:1233
13. Zhao LM, Zhang ZD (2008) *Scr Mater* 58:283
14. Chen YC, Nakata K (2008) *Scr Mater* 58:433
15. Liu L-M, Wang H-Y, Zhang Z-D (2007) *Scr Mater* 56:473
16. Liu L, Wang H, Song G, Ye J (2007) *J Mater Sci* 42:565. doi:10.1007/s10853-006-1068-6
17. Messler RW (2002) *Ind Robot* 29:138
18. Mackwood AP, Craferb RC (2005) *Opt Laser Technol* 37:99
19. Anisimov SI, Khokhlov VA (1996) *Instabilities in laser–matter interaction*. CRC, Boca Raton
20. Landau LD, Lifshitz EM (1980) *Statistical physics, part I*. Pergamon, Oxford
21. Semak V, Matsunawa A (1997) *J Phys D Appl Phys* 30:2541